

# A Core Splice Film You Can Handle

## **3M™ Scotch-Weld™ Core Splice Adhesive Film AF 3074 FST**

3M Scotch-Weld Core Splice Adhesive Film AF 3074 FST brings reliability and efficiency to your manufacturing process. Consistent expansion across cure profiles and excellent mechanical and FST properties make it suitable for a wide variety of interior and aero-structure applications. The optimal balance of tack and reposition-ability, easy cutting, and the ability to be shipped and stored at room temperature make it ideal for everyone from the supply chain to the shop floor.

# A New Approach to Core Splice

This epoxy-based, low-density splice film can be stored and transported unfrozen for up to six months, and its high and repeatable expansion rates deliver reliable consistency across individual assemblies and entire jobs. The result: more flexible production planning, faster production and reduced weight per part.

- Repeatable expansion rates add consistency to the parts
- Low density of 0.4 g/cm<sup>3</sup> @ free expansion
- Less sensitive to heat and humidity
- Less cold flow keeps cut edges smooth and gloves clean
- Up to six months shelf life and shop life at room temperature
- Enables non-refrigerated transport
- Classified non-dangerous good – can be transported by air
- Co-curable film is compatible with 120°C and 180°C cure cycles with wide service temperatures from -55°C up to 135°C



Panel Application

## Applications for core splicing and reinforcement:

- Primary and secondary structures
- Interior monuments
- Engine nacelle

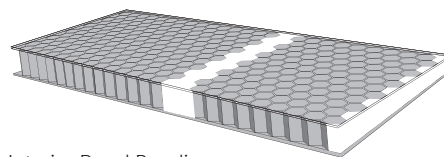

Interior Panel Bonding

Engine Nacelle Structure

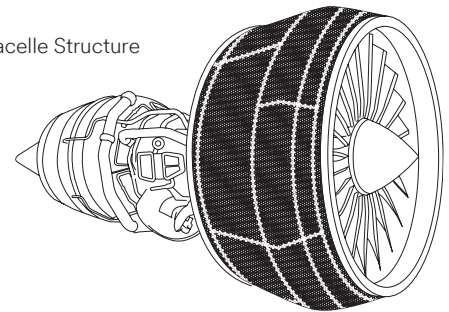

## Fully Backed by 3M Technical Service and Support

Get what you need, when you need it... Contact your 3M Aerospace sales specialist for more information on 3M™ Scotch-Weld™ Core Splice Adhesive Film AF 3074.

**Product Use:** Many factors beyond 3M's control and uniquely within user's knowledge and control can affect the use and performance of a 3M product in a particular application. Given the variety of factors that can affect the use and performance of a 3M product, user is solely responsible for evaluating the 3M product and determining whether it is fit for a particular purpose and suitable for user's method of application.

**Warranty and Limited Remedy:** 3M warrants that each 3M product meets the applicable 3M product specification at the time 3M ships the product. 3M MAKES NO OTHER EXPRESS OR IMPLIED WARRANTIES OR CONDITIONS, INCLUDING ANY IMPLIED WARRANTY OR CONDITION OF MERCHANTABILITY OR FITNESS FOR A PARTICULAR PURPOSE. If a 3M product does not conform to this warranty, the sole and exclusive remedy is, at 3M's option, replacement of the 3M product or refund of the purchase price. **Limitation of Liability:** Except for the limited remedy above, and except to the extent prohibited by law, 3M will not be liable for any loss or damage arising from or related to the 3M product, whether direct, indirect, special, incidental, or consequential, regardless of the legal or equitable theory asserted.

**Limitation of Liability:** Except where prohibited by law, 3M will not be liable for any loss or damage arising from the 3M product, whether direct, indirect, special, incidental or consequential, regardless of the legal theory asserted.



3M Automotive and Aerospace  
Solutions Division  
3M Center  
St. Paul, MN 55144-1000

General & Technical Information  
1-800-235-2376  
3M.com/Aerospace

3M and Scotch-Weld are trademarks of 3M Company.

Please recycle. Printed in USA  
© 3M 2018. All rights reserved.