

MIXPAC™ DP2X 400

400 ML CARTRIDGE DISPENSER

Indicator Rod

To quickly see how much material is remaining in the cartridge

Mounting Hook

To suspend dispenser

Cartridge Release Button

Conveniently located to provide easiest cartridge ejection

Trigger

Ergonomic trigger for more comfort

Plunger Retract Button

Easily accessible with one hand

Regulator

Adjust output force



FEATURES

- Universal conversion kits with interchangeable cartridge trays and plungers
- Quick exhaust
- Integrated anti-drip feature
- Ergonomically designed

BENEFITS

- Quick ratio exchange and use with DM2X and DP2X tools
- High precision and dispensing accuracy
- No oozing or dripping
- Fatigue free operation for longer periods of time

APPLICATIONS



PRODUCT BY RANGE



THE DP2X 400 IS A PNEUMATIC DISPENSER FOR ACHIEVING ACCURATE AND REPEATABLE RESULTS WHILE WORKING WITH MAXIMUM COMFORT.

SPECIFICATIONS

- Weight 2.66 kg / 5.87 lbs
- Length: 486 mm / 19.1 in
- Maximum Thrust: 5.0 kN
- Tool material: cast aluminium and reinforced nylon
- Cartridge capacity: 400 mL
- Cartridge ratio: 1:1 / 2:1 / 4:1 / 10:1
- Air inlet: 1/4 in NPT
- Max operating pressure: 6.8 bar/100 psi

DIMENSIONS

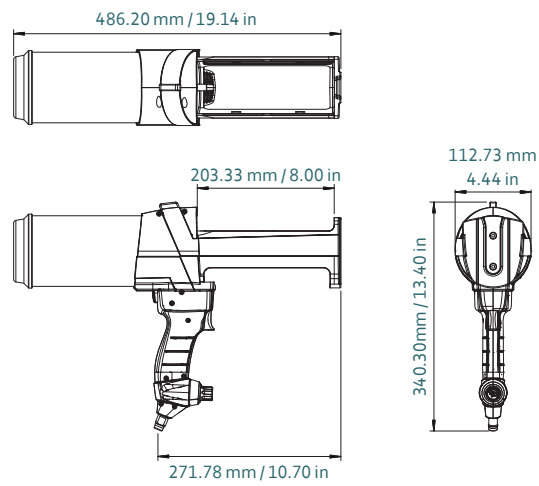

Part number	Article number	Ratio				Packaging
		1:1	2:1	4:1	10:1	
DP2X 400-01-50-01	165864	✓	✓			Packed individually 1 unit per master carton
DP2X 400-04-50-01	165865			✓		
DP2X 400-10-50-01	165866				✓	

MATCHING MIXPAC™ SIDE-BY-SIDE CARTRIDGES

C-SYSTEM / F-SYSTEM



C-System / F-System
400 mL / 1:1 PP/PA



C-System / F-System
400 mL / 2:1 PP/PA



C-System / F-System
400 mL / 4:1 PP/PBT



C-System / F-System
400 mL / 10:1 PP/PBT

CONVERSION KITS

CKX 400-01-01, CKX 400-04-01, CKX 400-10-01

MATCHING ACCESSORIES

All accessories are displayed on 16.