

CBM 25

50 ML CARTRIDGE DISPENSER

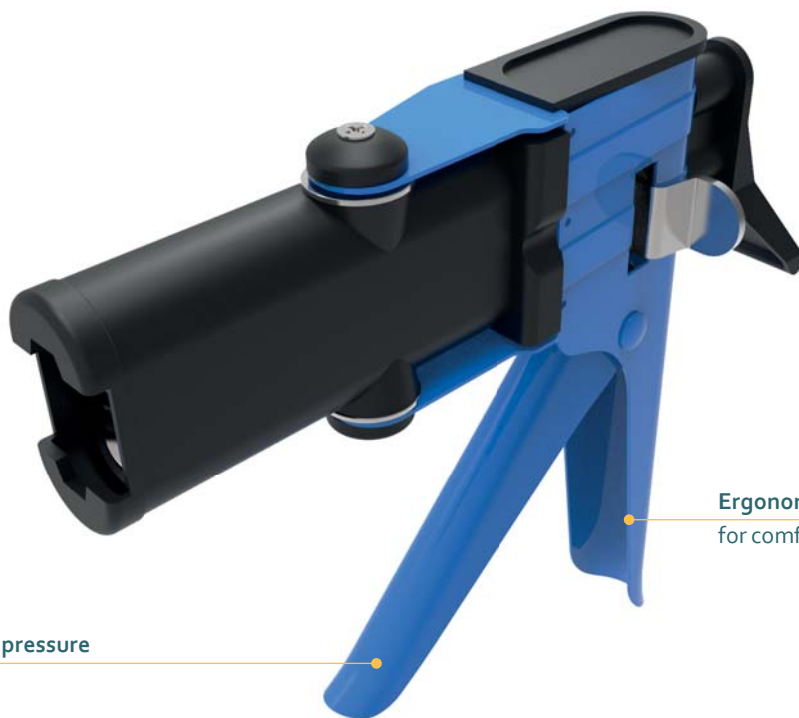

Ergonomic handle and trigger provide for comfort and minimum fatigue

Minimum trigger pressure for effortless use

Model shown: CBM 25 50 mL

FEATURES

- Simple breech loading mechanism
- Compact design
- Customization possible

BENEFITS

- Full cartridge support
- Light and maneuverable
- Customer labelling

APPLICATIONS



Bonding

Sealing

PRODUCT BY RANGE



CBM 25

THE CBM 25 IS A 2-COMPONENT MANUAL DISPENSER, ITS COMPACT LIGHTWEIGHT DESIGN COMES WITH AN EASY LOADING BREECH GIVING YOU FULL CARTRIDGE SUPPORT.

SPECIFICATIONS

- Weight: 0.43 kg / 0.9 lbs
- Frame Length: 96 mm / 3.8 inch
- Maximum Thrust: 2.5 kN
- Handle Material: Epoxy Coated Steel
- Frame Material:
Glass Fiber Reinforced Nylon
- Tool Component Approvals: REACH
- Cartridge Capacity: 50 mL (1.7 oz)
- Cartridge Ratio: 1:1
- Mechanical Advantage Ratio: 12:1
- Viscosity: Medium
- Standard Color: Black/Blue
- Customized versions: Yes

DIMENSIONS

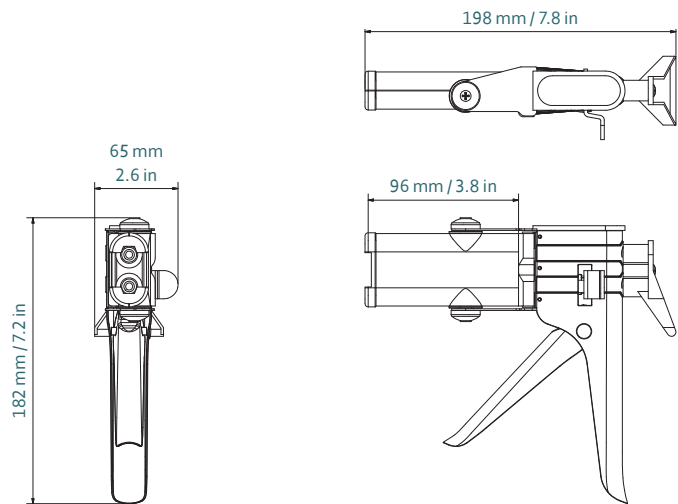

Part number	Article number	Packaging
DM2C 50-01-r12-001	159896 / M 25 (US)	25 per Box

MATCHING MIXPAC™ SIDE-BY-SIDE CARTRIDGES



A-System/B-System
50 mL / 1:1 PP/PA

COMPATIBLE SIDE-BY-SIDE CARTRIDGES

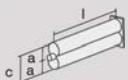

Plastic Cartridge
50 mL / 1:1 PP/PBT

1:1	mm	inch
l	99.7	3.93
a	Ø 21.0	Ø 0.83
c	46.0	1.81

CONVERSION KITS

MATCHING ACCESSORIES