

AIRFLOW™ 2 CBA R50

50 ML CARTRIDGE DISPENSER

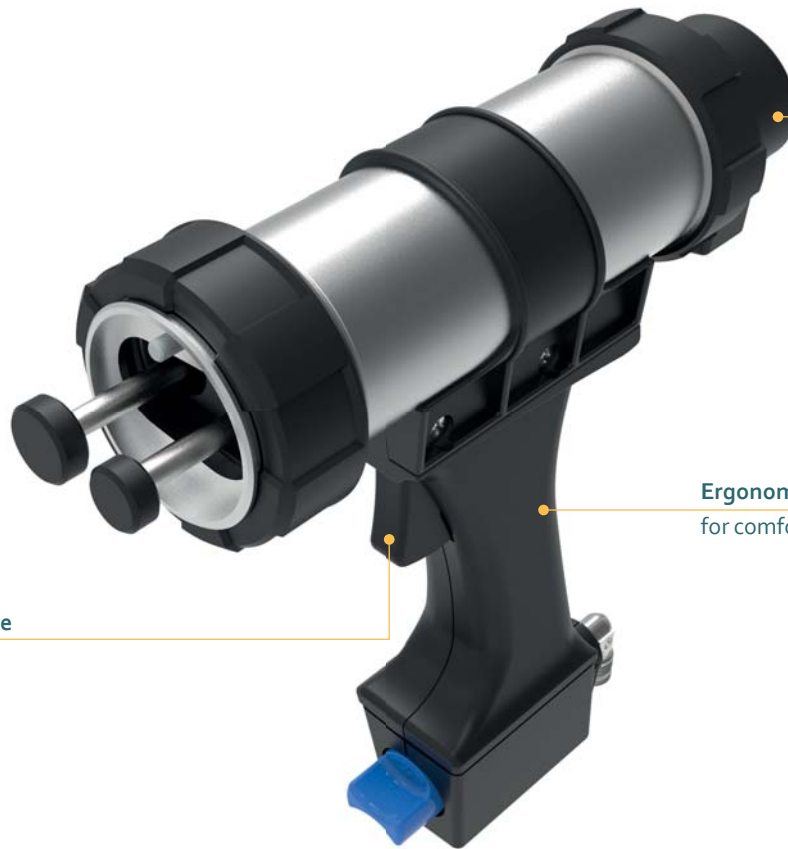

Quick exhaust
prevents run on

Ergonomic design
for comfort and minimum fatigue

Minimum trigger pressure
for effortless use

Model shown: AirFlow 2 CBA R50 50 mL

FEATURES

- Adjustable air regulator
- Minimum trigger pressure
- Air return as standard
- Quick exhaust valve
- Customization possible

BENEFITS

- Ensures precise controlled pressure
- For effortless use and minimum fatigue
- Fast, accurate, effortless application
- Prevents run-on
- Customer labelling

APPLICATIONS

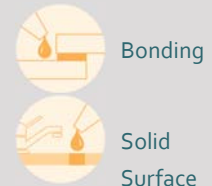

PRODUCT BY RANGE



AirFlow 1
CBA 25

AirFlow 1
CBA R50

AirFlow 1
CBA S50

AirFlow 2
CBA R50

AirFlow 2
CBA S50

THE AIRFLOW 2 CBA R50 2-COMPONENT PNEUMATIC DISPENSER OFFERS FAST, ACCURATE AND EFFORTLESS APPLICATION. WHILE THE CARTRIDGE HOUSING GIVES OPTIMAL SUPPORT FOR 50 ML R-TYPE CARTRIDGES.

SPECIFICATIONS

- Weight: 2.2 kg / 4.81 lbs
- Maximum Thrust: 1.5 kN
- Maximum Pneumatic Pressure: 3.4 bar / 50 psi
- Air Consumption: 40 litres/min
- Handle Material: Glass Fiber Reinforced Nylon
- Cartridge Holder Material: Glass Fiber Reinforced Nylon
- Tool Component Approvals: CE, REACH
- Cartridge Capacity: 50 mL (1.69 oz)
- Cartridge Ratio: 1:1, 2:1, 10:1
- Viscosity: Low
- Standard Color: Black/Silver
- Customized versions on demand

DIMENSIONS

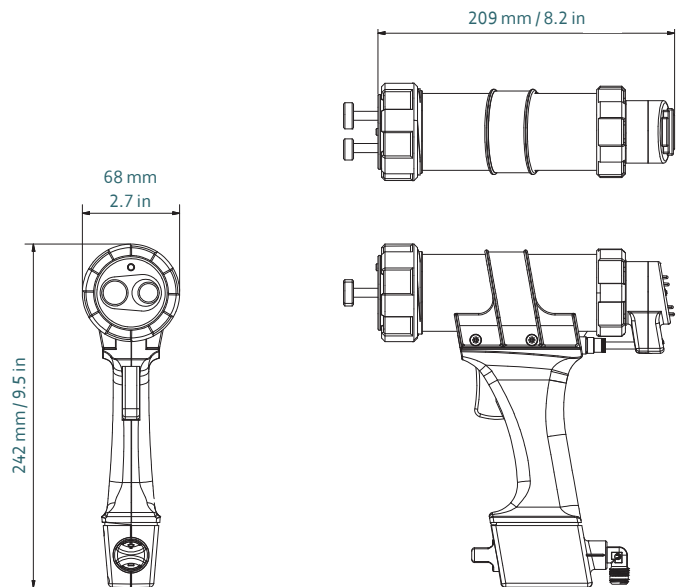

Part number	Article number	Packaging
DP2C 050-12-150-201	177754 (1:1, 2:1)	10 per Box
DP2C 050-10-150-201	177765 (10:1)	10 per Box

MATCHING MIXPAC™ CARTRIDGES



A-System/B-System
50 mL / 1:1 PP/PA



A-System/B-System
50 mL / 2:1 PP/PA



A-System
50 mL / 10:1 PP/PA

COMPATIBLE CARTRIDGES

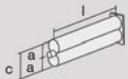

Rectangular Flange Cartridge
50 mL / 1:1 PP / PBT

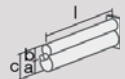

Rectangular Flange Cartridge
50 mL / 2:1 PP / PBT

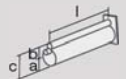

Rectangular Flange Cartridge
50 mL / 10:1 PP / PBT

1:1	mm	inch
l	99.7	3.93
a	Ø 21.0	Ø 0.83
c	46.0	1.81

2:1	mm	inch
l	108.5	4.27
a	Ø 25.0	Ø 0.89
b	Ø 18.0	Ø 0.71
c	46.0	1.81

10:1	mm	inch
l	102.0	4.02
a	Ø 30.0	Ø 1.18
b	Ø 10.8	Ø 0.43
c	44.0	1.73

CONVERSION KITS

MATCHING ACCESSORIES